

# Model: CSCI-IP67

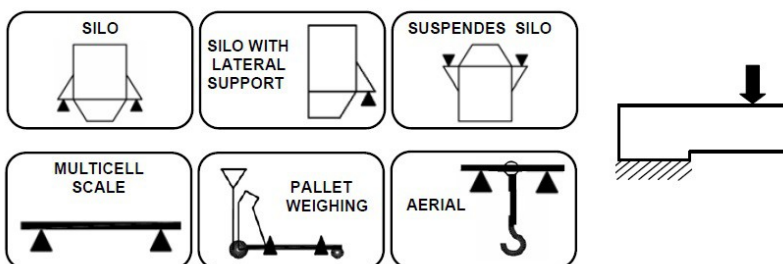

**APPLICATION:**  
Multi-cell scales

**CAPACITY RANGE:**  
750kg - 1000kg – 1500kg

**MATERIAL:**  
Stainless Steel

**ENVIRONMENTAL PROTECTION:**  
IP67

**APPROVALS:**  
CE 3000 Div - TC6177  
OIML 3000 Div - R60/2000-NL 1-03.02

**CHARACTERISTICS**  
Construction using stainless steel.  
High quality protection barrier using special silicones.  
Mounting compatibility.

**APPLICATIONS**  
The CSCI-IP67 model is manufactured to maintain its performance capabilities in the environmental conditions existing in industries, where tasks and cleaning demand a good environmental protection.  
If the required capacities are under 750kg, select the CFSI-IP67 model which is mechanically compatible and reaches from the 50kg to 500kg capacity.

**OPTIONS**  
Length of the cable is optional.  
Consult for special requirements.



TEFLÓN® protects all the internal cables

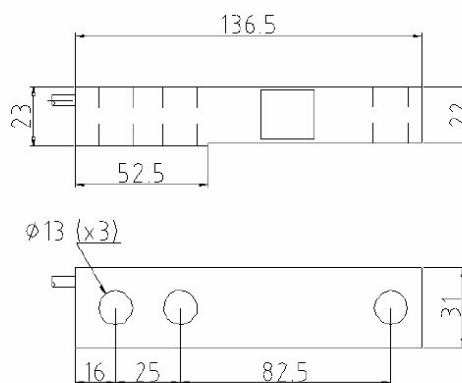

Dimensions in mm

